

LogiTALKER

Voice Keyer

OWNER'S MANUAL

Idiom Press

www.idiompres.com

PO Box 1015, Merlin, OR 97532-1015 USA • +1 541-956-1297

Preface

Thank you for purchasing our *LogiTALKER*, a stand-alone voice keyer for your radio.

To put the keyer in service you will need at least two cables. One cable goes from the “Mic Out” RJ45 modular connector on the rear of the *LogiTALKER* to the microphone input of your radio. Cables are available from Idiom Press for connecting the *LogiTALKER* to radios with round 8-pin mic connectors or RJ45 modular connectors.

The second cable will be a 2.5 mm inner diameter, 5.5 mm outer diameter DC coaxial power plug to a 12–14 VDC regulated power supply. The center pin is positive, the shell is negative. Caution: Do **NOT** use typical wall-wart “12 volt DC” supplies. These supplies often put out unfiltered pulsating DC, and frequently at voltages that can spike in excess of 15 volts, which can severely damage your *LogiTALKER* and void the warranty. Only use a regulated and well-filtered supply. Note that many transceivers have 12-volt outputs for auxiliary equipment – this is a good source. The 12 VDC or 13.8 VDC supply that powers your radio is also a good source.

Set-Up

You must configure the *LogiTALKER* to match your radio microphone and other operating parameters such as Beep on/off and Delay values. Refer to Figures 1-4 on the following pages as a guide to setting these jumpers.

An explanation of how the microphone configuration header JP1 works is in order. The left row of pins is for inputs, and for now let’s consider only that row of pins, and ignore the right row of pins. The pins labeled 1-8 are connected directly to the microphone input jacks’ pins 1-8, and the pins labeled “MIC”, “MIC-G”, “PTT”, and “PTT-G” are where the *LogiTALKER* gets the microphone, microphone ground, Push to Talk, and Push to Talk Ground input signals. You must use jumpers to connect “MIC”, “MIC-G”, “PTT”, and “PTT-G” to the correct microphone input jack pins.

Similarly, the right row of pins in JP1 is for outputs. Pins 1-8 are connected directly to the microphone output jack. Pins 9-12 have the output signals from the *LogiTALKER*, which you must connect to the correct output pins using jumpers.

Any JP1 pins 1-8 in the left row that aren’t connected to *LogiTALKER* input pins should be connected straight across to the corresponding pins of the right row. In that way, microphone functions that have nothing to do with the *LogiTALKER*, such as “UP” and “DOWN” buttons, continue to work normally.

The jumper configuration of the right row of pins of JP1 should be the mirror image of the jumper configuration of the left row of pins.

In this way, the *LogiTALKER* can be configured for just about any dynamic, condenser, or electret microphone that has an eight-pin modular plug. With the modular-to-Foster output cable, available separately from Idiom Press, the *LogiTALKER* can similarly be configured for just about any microphone that has an eight-pin Foster plug.

If for any reason you find it necessary to work out the configuration of a particular microphone by yourself, then it is essential to keep in mind that not all radio manufacturers use the same standard of which pin is defined as pin 1 for modular plugs. If the manufacturer of the radio numbers the pins

differently, then you must take that fact into account when calculating how to wire the jumpers in the LogiTALKER. See Figure 5.

Figure-1: Microphone Jumper Configuration

Radio	Model	JP1								JP2
		1	2	3	4	5	6	7	8	
Icom	IC-703, 706, 7000	J	12	9	10	11	J	J	J	On
	718, 725, 735, 746, 756, 7200, 7600, 7700, 7800	9	J	J	J	11	12	10	J	On
Kenwood	TS-50, 570, 850, 870, 2000	9	11	J	J	J	J	10	12	Off
	TS-480	J	J	10	11	12	9	J	J	Off
Elecraft	K3	9	11	J	J	J	J	10	12	Off
Ten-Tec	Omni VII, Orion II	J	J	J	J	12	11	10	9	Off
Yaesu	FT-450, 817, 857, 897	J	12	11	9	10	J	J	J	Off
	FT-847, 920, 950, 2000	J	J	J	J	12	11	10	9	Off
Flex-Radio	FLEX-1500, FLEX-3000	J	12	11	9	10	J	J	J	Off

“J” indicates a pass-thru jumper straight across JP1. In the table, 9 refers to “MIC”, 10 refers to “MIC G”, 11 to “PTT”, and 12 to “PTT G”.

Figure 2: Beep & Delay Jumper Configuration

Function	JP3	JP4
Beep On	1-2	-
Beep Off	2-3	-
Delay Range: 24-266 Seconds	-	1-2
Delay Range: 2-25 Seconds	-	2-3

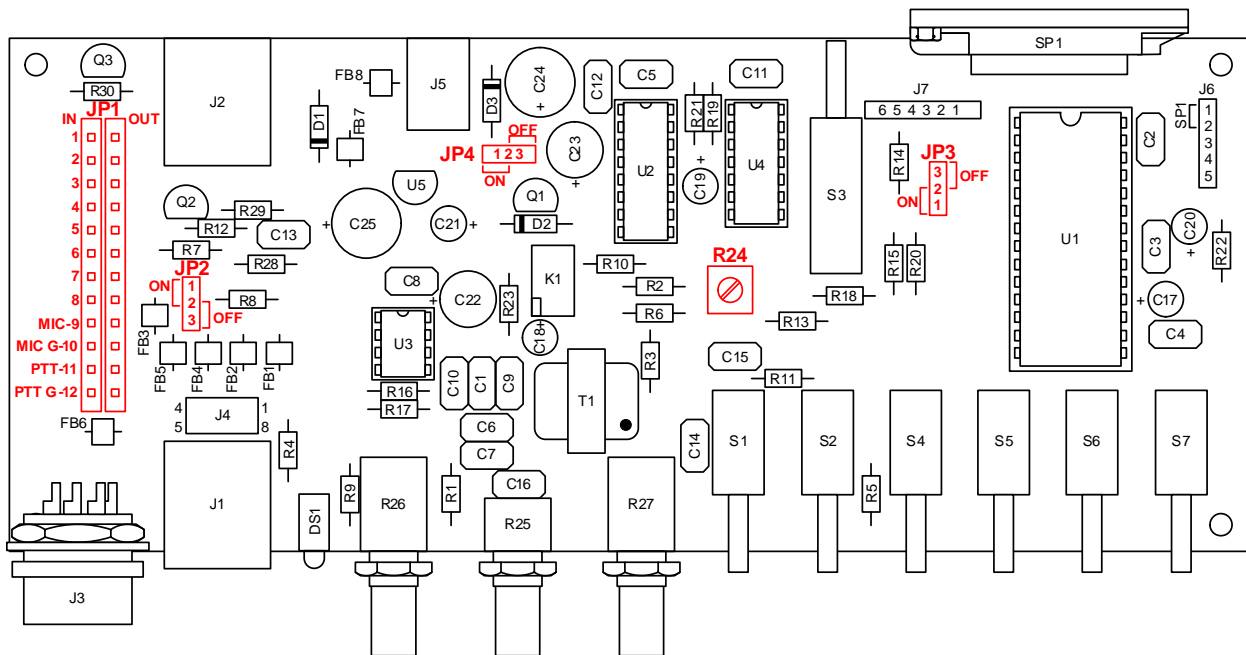

Figure 3 - PC Board Layout

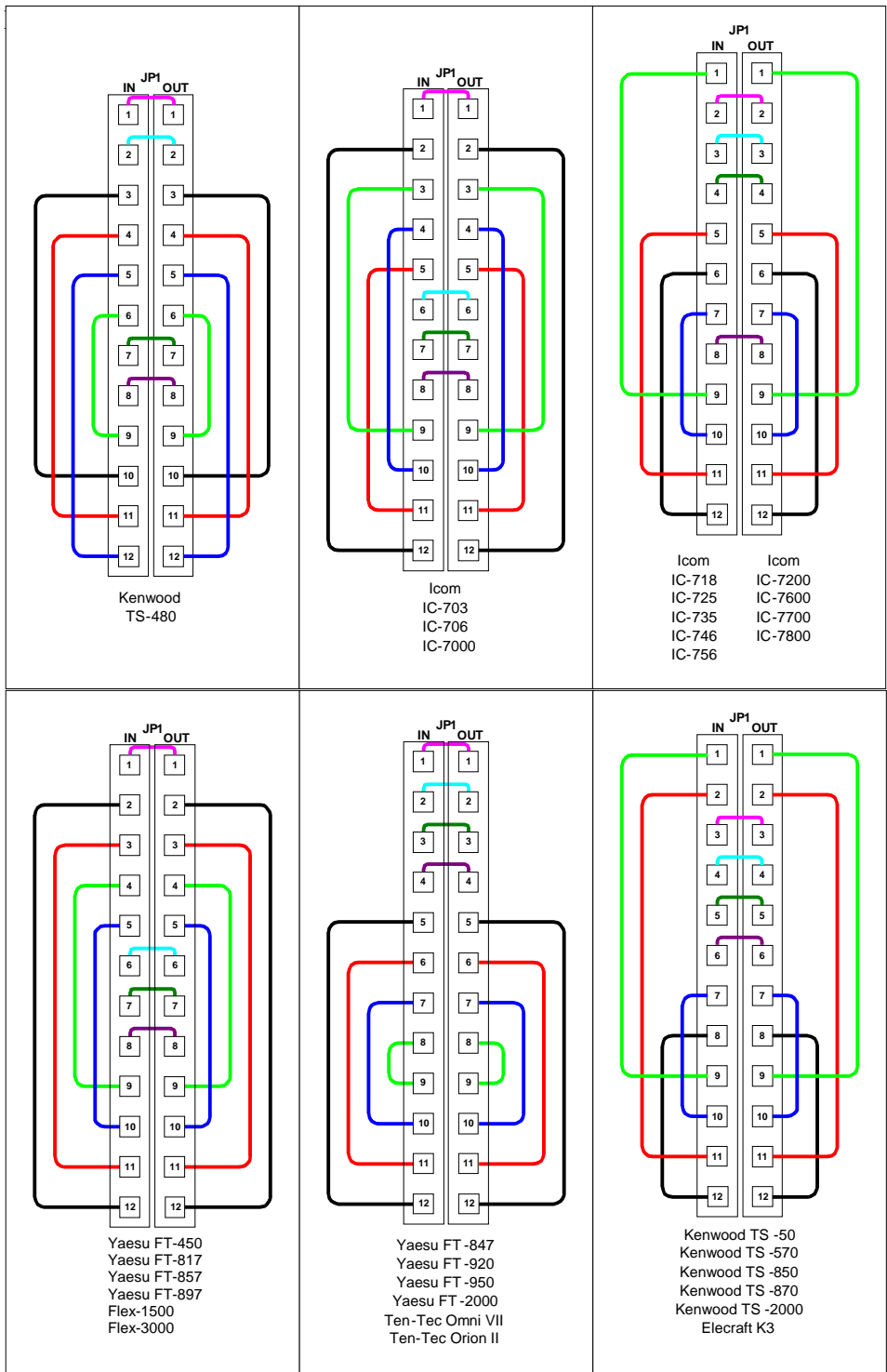

Figure 4

Setup (Continued)

- Remove the *LogiTALKER* cover by removing the two screws on each side and lift the cover off.
- Locate your radio in Figure 1 and Figure 4 and use the supplied jumper wires for configuring the mic wiring on JP1. JP1 is a dual 12-pin header located at the far left of the PC board. Starting with pin 1, place the wire connector over the pin and push it all the way down. Place the other end of the wire over the appropriate pin on the same header or opposite header if it is a pass-thru jumper, and push it all the way down. Continue until all 12 wires have been installed. (Note that the wire colors shown in Figure 4 do not correspond to the actual jumper wire colors.)

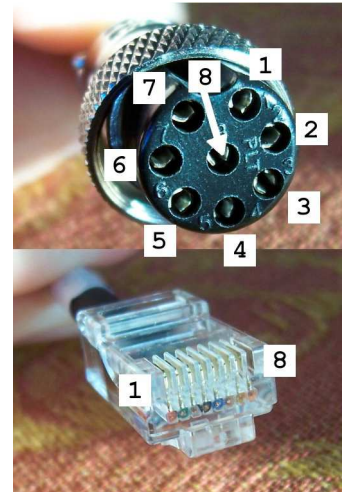

Figure 5

- If your radio is not listed in Figure 1, please contact Idiom Press for assistance. However, if you know the radio microphone wiring pinout you may be able to determine the jumpers from the following:
 - Elecraft mic pins labeled Up, Down, Function, and +8V or +5V are pass-thru signals and are jumpered straight across JP1 using the listed pin numbers.
 - Icom mic pins labeled Up/Down, Squelch, +8V, and Audio Out are pass-thru signals and are jumpered straight across JP1 using the listed pin numbers.
 - Kenwood mic pins labeled Up, Down, +8V, and N/C are pass-thru signals and are jumpered straight across JP1 using the listed pin numbers.
 - Ten-Tec mic pins labeled NC, and +10V are pass-thru signals and are jumpered straight across JP1 using the listed pin numbers.
 - Yaesu mic pins labeled Up, Down, +5V, and Fast are pass-thru signals and are jumpered straight across JP1 using the listed pin numbers.

Pins labeled Mic, Mic ground, PTT, and PTT ground are the signals used in the *LogiTALKER*. Jumper these pins to the corresponding pin labels (shown on the PC board Figure 3), and duplicate the jumpers on the both sides of JP1.

- Use the supplied jumper shorting block for configuring the mic bias voltage on JP2. Microphone bias voltages are required for all electret or condenser mics. Dynamic mics do not require a bias voltage. Place the shorting block across pins 1-2 to enable mic bias or across pins 2-3 to disable mic bias.
- Use the supplied jumper shorting block for configuring the beep enable on JP3 (see Figure 2 and 3). Place the shorting block across pins 1-2 to enable the beep or across pins 2-3 to disable the beep.

- Use the supplied jumper shorting block for configuring the message delay range on JP4 (see Figure 2 and 3). Place the shorting block across pins 1-2 for delays of 24-266 seconds or across pins 2-3 for delays of 2-25 seconds.
- While the cover is off, check the keyer's audio output level and the setting of trimpot R24. Connect your 12VDC power supply cable to the keyer and the mic cable from the keyer to the radio. Connect a dummy load to your radio's RF output.
- Set the *LogiTALKER* controls as follows:
 - Volume to 1/2 which applies power and lights the green LED
 - Transmit Level to 1/2
 - Delay fully CCW to Off
 - Mode pushbutton to Record
 - Transmit pushbutton to Off
- Press and hold the Message-1 pushbutton, speak a test message into the microphone, and then release the pushbutton when finished. On most radios the microphone PTT switch does not need to be pressed, and should not be pressed, to record a message. A single beep (if enabled) will signal the start and end of a successful recording. If two beeps are heard before releasing the pushbutton the recording time has been exceeded and the message should be recorded again.
- Next, set the Mode switch to Play and Transmit pushbutton to On
- Press and release the Message-1 pushbutton and adjust the Volume control for a comfortable level. (Adjust the distance to the microphone or speaking volume if the audio is distorted or weak and re-record the message). Play Message-1 and adjust the Transmit Level control to match the modulation level observed on a live microphone signal. Adjust trimpot R24 if the final Transmit Level setting is near the beginning or end of its range.
- When all jumpers and adjustments have been made and you are satisfied with the operation of the *LogiTALKER* and radio, re-install the cover and screws. Congratulations, set-up is complete!

Operation

You are now ready to record all of your messages. Note that this may be done without connecting the *LogiTALKER* to your radio. The final step is to connect your radio to an antenna and check the quality of the transmitted audio during a QSO and make any refinements as needed. Make a note of the final control settings for future use.

For contests, many users set Message-1 as a CQ message and reserve Messages 2-4 for common reports such as grid square, QTH, equipment, etc. If a response to your CQ is heard between intervals press the microphone PTT switch (suspending the Message-1 auto repeat) and begin transmitting. At the conclusion of the QSO press the Message-1 pushbutton to resume the repeating loop.

Press Message-1 and adjust the Delay for an interval of approximately 2-25 seconds (or 24-266 seconds) between messages. Press the microphone PTT switch at any time to halt playback of all messages and

stop the Message-1 repeat. Resume the auto repeat by pressing Message-1. Messages 2-4 do not have auto repeat and will play one time for each press of the pushbutton. The Message-1 auto repeat may also be switched off by turning the Delay control fully CCW. If a message is playing and its respective pushbutton is pressed the message will stop. If a message is playing and a different message pushbutton is pressed the keyer will beep, stop playback of the first message, and then play the new message after a short delay.

One warning: you will not be able to record messages with the *LogiTALKER* connected to a radio, and the radio powered off. In that case you can either turn the radio on and record messages, or disconnect the *LogiTALKER* from the radio and record messages.

Modifications

There are several modifications that the user can perform to customize the *LogiTALKER*. Refer to the schematic diagram at the end of this manual.

- More speaker volume – Add a 10 μ F/25V electrolytic capacitor (C26) and series 0-1.2K resistor (R26) from U3 pin 8 to pin 1. The lower the value of R26 the higher the maximum volume.
- Headphones – Add a headphone jack on the rear of the *LogiTALKER* using the available signals on J6. Speaker outputs are on pins 1-2.
- External Power Amplifier – Add an external power amplifier using the available audio and voltage pins on J6. Low level audio signals are on pins 4-5 and 12VDC is available on pin 3.
- Computer Messaging Control – Add the ability to control message playback from your computer's parallel port using the available pins on J7. Momentarily grounding pins 1-4 will playback messages 1-4.
- Change the Message-1 repeat delay range. Place shorting block across pins 1-2 on JP4 and replace C24 with a value of your choice. As shipped, C23=220 μ F and C24=2200 μ F.

$$\text{Delay}_{\min} = R_{\min} \times (C23 + C24)$$

$$R_{\min} = R11 = 10 \text{ k}\Omega$$

$$\text{Delay}_{\min} = (10 \times 10^3) \times (220 \times 10^{-6} + 2200 \times 10^{-6}) = 24 \text{ seconds}$$

$$\text{Delay}_{\max} = R_{\max} \times (C23 + C24)$$

$$R_{\max} = R27 + R11 = 100 \text{ k}\Omega + 10 \text{ k}\Omega = 110 \text{ k}\Omega$$

$$\text{Delay}_{\max} = (110 \times 10^3) \times (220 \times 10^{-6} + 2200 \times 10^{-6}) = 266 \text{ seconds}$$

Front Panel

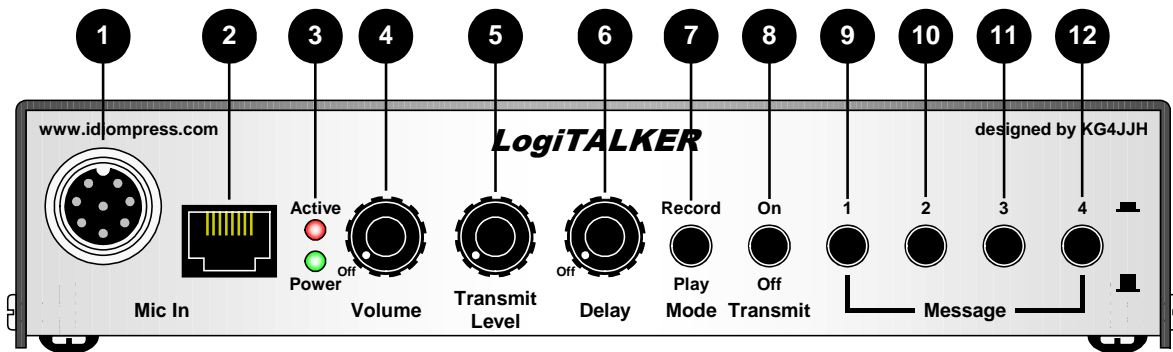

1. **Mic In** - Connects your radio microphone's round 8-pin connector to the *LogiTALKER*.
2. **Mic In** - Connects your radio microphone's modular RJ45 connector to the *LogiTALKER*.
3. **Active** - Red LED flashes to indicate the *LogiTALKER* is playing or recording a message.
4. **Power** - Green LED indicates the *LogiTALKER* is powered on.
5. **Volume** - Switches *LogiTALKER* power on/off and controls the volume of the internal amplifier and speaker.
6. **Transmit Level** - Sets the audio output level to your radio.
7. **Delay** - Sets the amount of delay time between repeats for Message 1. Delays times are configured by jumper JP4. Turn completely CCW to turn delay off.
8. **Record/Play** - Locking pushbutton, "In" to record messages, "Out" to play messages.
9. **Transmit On/Off** - Locking pushbutton; "In" keys the radio during message recording or playback, "Out" to prevent keying the radio during message recording or playback.
10. **Message 1** - Momentary pushbutton, a momentary press plays Message-1. If Delay is turned on it will start the Message-1 repeat delay cycle.
11. **Message 2** - Momentary pushbutton, a momentary press plays Message-2.
12. **Message 3** - Momentary pushbutton, a momentary press plays Message-3.
13. **Message 4** - Momentary pushbutton, a momentary press plays Message-4.

Rear Panel

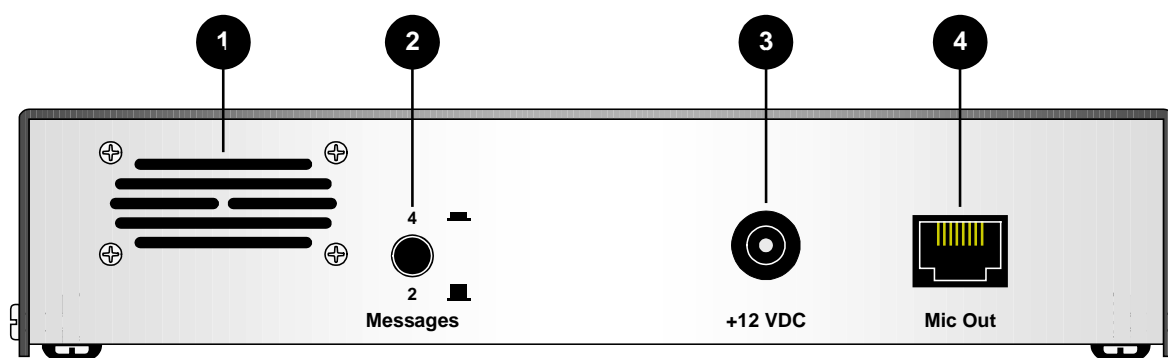

1. Internal speaker for monitoring message playback.
2. **2/4 Messages** - Locking pushbutton, selects between 2 or 4 messages. “In” selects 4 message mode and “Out” selects 2 message mode. Messages must be recorded with this switch in the desired position. Changing switch positions after messages have been recorded will result in incorrect playback pitch of the recorded message.
3. **+12 VDC** - 2.5mm x 5.5mm input jack for *LogiTALKER* 12 VDC power.
4. **Mic Out** - Connects the output of the *LogiTALKER* to the microphone input of your radio using the appropriate adapter cable.

Specifications

Overall Dimensions (excluding cables)	1.75" H x 7.375" W x 4" D
Weight	14 oz.
DC Power requirements	13.8 VDC nominal < 200mA (reverse polarity protected)
2 Message Mode:	
Sampling Frequency	8.0 kHz
Input Bandwidth	4.0 kHz
Message Length	16 seconds per message
4 Message Mode:	
Sampling Frequency	6.4 kHz
Input Bandwidth	3.2 kHz
Message Length	10 seconds per message
Microphone Input Voltage	30mV peak-to-peak, maximum
PTT contact rating	2 A @ 30 VDC, maximum

Features

- 2 or 4 Messages
- Built-in audio amplifier and speaker
- Message pushbuttons
- Audible beep prompts
- Play/Record switch & LED
- Transmit On/Off switch
- Uses the radio microphone
- Record and play messages without a radio connection
- Transformer isolated audio output with level control and automatic PTT switching
- Message-1 repeat with 2-25 or 24-266 second delay interval with on/off control
- Suitable for any radio with appropriate RJ45 adapter cables for the radio

Warranty

Your *LogiTALKER* is warranted against defects in material and workmanship for 90 days from the date of purchase from Idiom Press or from an authorized Idiom Press dealer.

This warranty does not cover damage or failure caused by or attributable to Acts of God (such as nearby lightning strikes), abuse, misuse, improper or abnormal usage, improper configuration, faulty construction, use of acid core or water soluble resin solders in construction, faulty installation, improper maintenance, application of excessive voltage, or improper construction or repair.

Idiom Press is not responsible or liable in any way for direct, indirect, special or consequential damages arising out of or in connection with the use or performance of the product or other damages with respect to loss of property, loss of revenues or profit, or costs of removal, installation or reinstallation.

Except as provided herein, Idiom Press makes no express warranties, and any implied warranty of merchantability or fitness for a particular purpose is limited in its duration to the duration of the written limited warranties set forth herein.

Always contact Idiom Press at **info@idiompress.com** before returning a unit! For repair, warranty or otherwise, contact Idiom press for instructions. Always include a letter carefully describing the problem. If the unit was purchased from a dealer, include a copy of your sales receipt.

Idiom Press
PO Box 1015
Merlin OR 97532-1015
USA
+1 (541) 956-1297
www.idiompress.com

Schematic Diagram

